

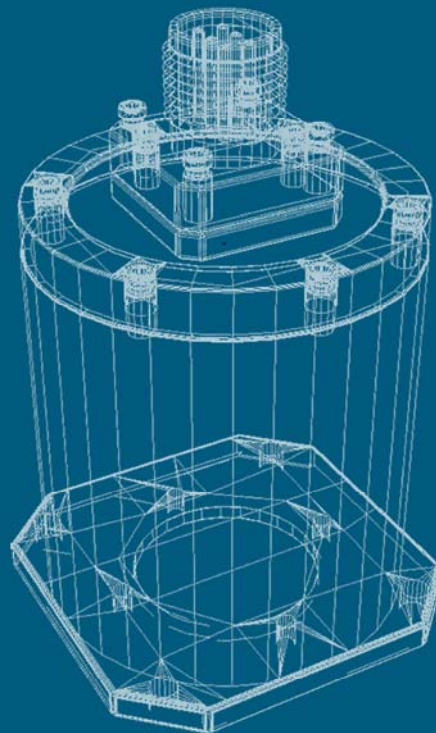

MiniTilt

Technical Manual



CDL
Silverfield House
Claymore Drive
Aberdeen
AB23 8GD

Tel: +44 (0) 1224 706655
Fax: +44 (0) 1224 709840
Web: www.cd ltd.net
Email: info@cd ltd.net

Document Rev B

Table of Contents

Introduction	3
1.1 General Description	3
1.2 OEM Version.....	4
MiniTilt Checkout Procedure	6
2. Specifications.....	8
2.1 MiniTilt Specifications	8
3. Connections	9
3.1 OEM version connector	9
3.2 Surface version connector	9
3.2 Subsea version connector.....	9
3.4 Connections.....	9
4. Data Output Formats	10
4.1 Chassis grounding.....	10
4.2 Option switches.....	10
OPT2 Option Switch 2 Swap Polarity	10
OPT3 Option Switch 3 Heading / No Heading	10
OPT5 Option Switch 5 Hundreds Digit.....	11
OPT6 Option Switch 6 Hundredths Digit.....	11
4.3 Data Output Information	11
5. Mounting Arrangements	12
5.1 OEM version.....	12
5.2 Surface and Subsea versions.....	12
5.3 MiniTilt Zero Setting	13
6. Topside Display (optional)	13
6.1 The CDLtd Data Display Unit (DDU)	13
6.2 MiniTilt display software.....	14
6.3 Connections.....	15
6.4 Setup procedure	15
CONTACTING CDL.....	16

Introduction

1.1 General Description

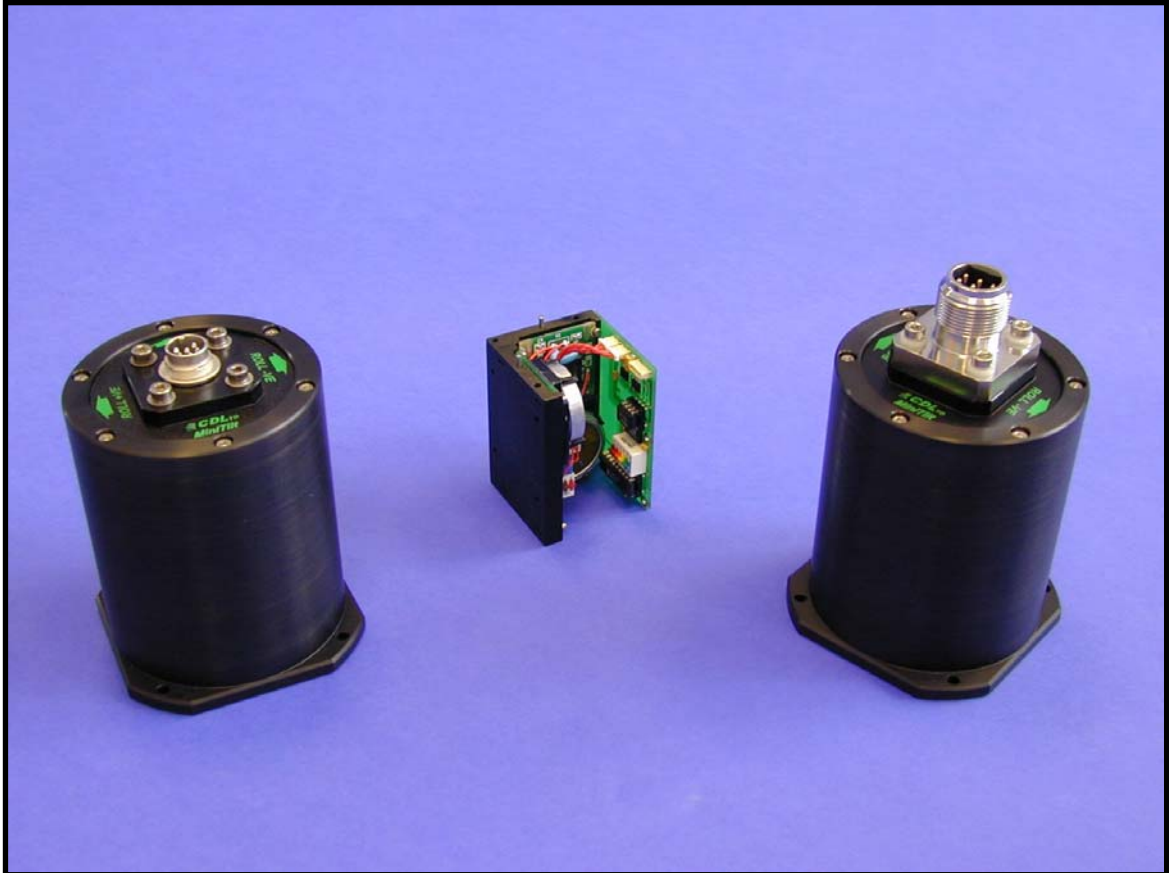

The CDLtd MiniTilt is a surface or subsea Pitch and Roll sensor for use in the offshore survey industry. It provides an accuracy of 0.05 degrees in both axes over the full 360 degree range. The unit can be provided in a surface or subsea (3000m rated) package or can be supplied in an accurately machined mounting frame for OEM applications.

The product has the following features:

- High Accuracy (0.05 degrees)
- Low cost
- 3000m depth rated
- Surface and OEM versions
- Full 360 degree range
- Gyro heading input
- 32 switchable output data strings

The MiniTilt is highly compatible with existing Pitch and Roll sensors. It uses a bank of 6 internal option switches to provide a total of 32 different output data formats. Previously, installation problems have occurred where pitch and roll sensors do not agree on polarity selection. The MiniTilt has the ability to swap polarity to simplify the mechanical installation. It can also read gyro input data in a range of data formats in order to produce a complete three axis data string.

The MiniTilt housing is machined from solid aluminium to provide a high quality and extremely rugged case. Hard anodisation gives protection from corrosion in the subsea environment.

1.2 OEM Version

The OEM version of MiniTilt contains all the functionality of the full product but is supplied without external packaging of any kind.

The two angle sensors are mounted on an 'L' section angle plate with provision for adjustment of cross-axis settings. The cross-axis settings are adjusted at the factory and should not require any re-adjustment.

The 'L' plate has 4xM3 mounting holes tapped into each face to allow attachment to any vertical surface. Additionally, CDL can provide circular mounting plates which attach to the top or bottom of the 'L' section and allow the OEM MiniTilt to be attached to any horizontal surface.

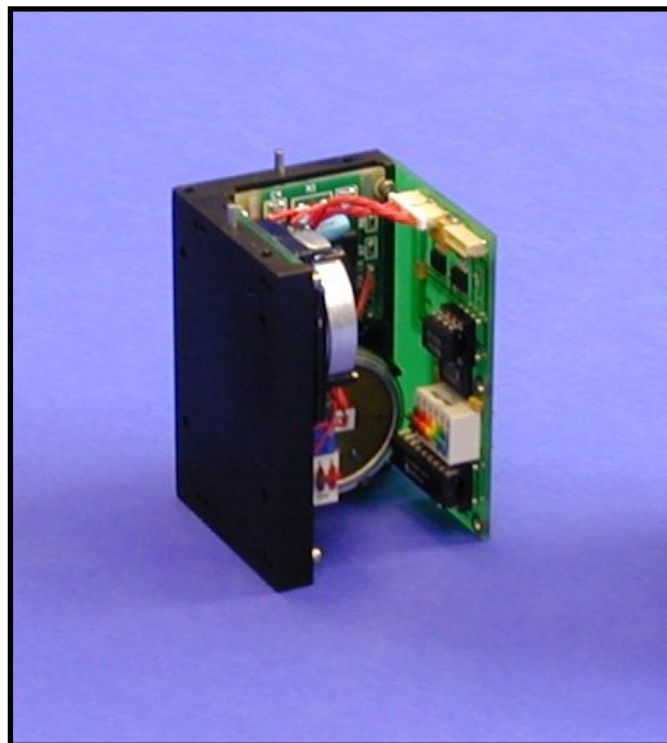

The 'L' plate has locating pins fitted to both top and bottom. These pins can be used to ensure accurate rotational alignment and also to give an accurate reference for cross-axis calibration.

Connection to the OEM MiniTilt is by way of a JST 8-way connector.

The option switches are easily accessible to the operator.

The control micro (PIC16F84) and the opto-isolator are DIL mounted for easy firmware upgrades and easy change out of gyro receive circuit after cable cuts etc.

1.3 Surface version



The surface version of MiniTilt contains a complete OEM unit inside an anodised aluminium housing. The housing has 4 mounting holes machined into the base which can be used to attach the MiniTilt to any flat surface.

1.4 Subsea version (3000m)



The subsea version of MiniTilt contains a complete OEM unit inside an anodised aluminium housing depth rated to 3000m in sea-water. The housing is sealed with a single piston 'O'-ring which should be cleaned and re-greased whenever the housing is opened.

1.5 Deepwater version (5000m)

The deepwater version of MiniTilt is identical to the subsea version in every way except that the housing is machined from Titanium rather than Aluminium in order to achieve the superior depth rating.

1.6 Check-out and calibration

The MiniTilt system should be given a full factory calibration every 12 months. The factory will return the unit with a factory calibration sheet showing the sensor performance at all angles, as well as figures for cross-axis sensitivity and temperature drift.

Between factory calibration checks, the MiniTilt can be checked after each job using the following procedure.

MiniTilt Checkout Procedure

1. Inspect housing frame for signs of mechanical damage
2. Inspect connector for bent pins, damage or dirt. Clean and grease if necessary.
3. Open housing, check for any physical damage to PCB or sensors
4. Use test cable wired as follows (into computer and 12V PSU):

<u>MiniTilt</u>	<u>Function</u>	<u>Computer</u>
1	+12Vdc	
2	GND	5
5	RS232 OP	2

5. Switch on test cable at power supply and check that MiniTilt draws less than 10mA.
6. Run terminal program on PC and set to 9600,8,1,N. Check that data is displayed on screen each 580msec (approx).
7. Test each option switch for correct functionality (using explanations in chapter 4)
8. Make a current loop tester according to the diagram below.

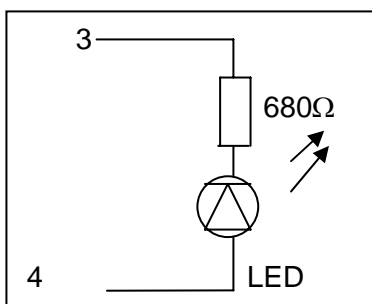

9. Connect tester between pins 3 and 4 on the MiniTilt. If the LED flashes then the current loop driver is functioning correctly.



2. Specifications

2.1 MiniTilt Specifications

Range	360° (full range)
Resolution	0.01°
Accuracy	0.05(°
Calibration points	128 (per sensor)
Temperature coefficient	0.003° per °C
Repeatability	0.03°
Hysteresis	0.05° (average)
Noise	0.01°
Frequency response	0.4 seconds (typical)
Output rate	580 msec
Humidity sensitivity	Conformally coated
Power Input	5-30 Vdc
Current consumption	<10mA (@ 12Vdc typical)
Temperature Range	Operating: -30°C to +55°C Storage -55°C to +65°C
Data Output	RS232 and Current Loop
Gyro Input	Current Loop
Baud Rate	9600
Data Bits	8
Stop bits	1
Parity	None

3. Connections

3.1 OEM version connector

Connection to the OEM version is by way of a JST 8 way 1mm pitch connector (mating connector - RS part no. 311-6546 Single crimp connection – RS part no. 311-6675)

3.2 Surface version connector

Connection to the surface version is by way of an 8 way Binder series connector (mating connector - RS part no. 261-6045). This connection system provides moisture protection to IP67

3.2 Subsea version connector

Connection to the subsea version is by way of a Mini Burton subsea connector (part number 5501-1508).

3.4 Connections

All connectors are 8-way with the following pin functions.

Pin 1	Vin (5Vdc-30Vdc)
Pin 2	GND
Pin 3	CL Hi (Output)
Pin 4	CL Lo (Output)
Pin 5	RS232 Out
Pin 6	RS232 In
Pin 7	CL Hi (Gyro Input)
Pin 8	CL Lo (Gyro Input)

The current loop and RS232 outputs carry an identical ASCII data string. The current loop input is wired to an on-board opto-isolator. The MiniTilt internal firmware is factory set to read an input data string from the Robertson SKR82 gyrocompass. This firmware can be changed at the factory to read gyro data from a large range of other gyros in either current loop, RS232 or TTL formats.

4. Data Output Formats

The control board in the MiniTilt is fitted with a bank of 6 option switches which can be used by the operator to configure the MiniTilt system.

All switches have a cumulative effect on the output data string. This provides a total of 32 user-configurable outputs which should allow the MiniTilt to provide the exact data string needed for each application.

If it is necessary to produce data outputs which are not available via the option switches, new firmware can be provided by CDL for this purpose.

Data is output in ASCII format simultaneously by RS232 and current loop methods.

4.1 Chassis grounding

OPT1 Option Switch 1 Connect / disconnect MiniTilt circuit GND from chassis.

The operator can decide using option switch 1 if the circuit GND of the MiniTilt is to be connected to the chassis GND. This would normally be set to 'on' but if large amounts of noise exists on the chassis GND the switch can be set to 'off' to improve system performance.

4.2 Option switches

OPT2 Option Switch 2 Swap Polarity

Setting this switch to 'on' will swap the polarity of both the Pitch and Roll readings. i.e. positive becomes negative and negative becomes positive. This can be useful for providing complete compatibility with other Pitch & Roll sensors. It can also be used in situations where it is difficult to mount the OEM unit in a particular orientation because of physical restrictions.

OPT3 Option Switch 3 Heading / No Heading

This switch is used to enable/disable the heading feature. When switched to 'off', heading information is added to the output data string. The heading information is read via the on-board current loop converter (factory set to SKR82 format).

OPT4 Option Switch 4 Decimal Points

The function of this switch is to decide whether decimal points are included in the output data string. When switched to 'off', all data will carry ASCII decimal points in the correct position.

OPT5 Option Switch 5 Hundreds Digit

This switch controls the inclusion of the hundreds digit in the output data string. The MiniTilt can read a full 360° angle range in each axis, and, as such requires to have the ability to output an angle greater than 99.99°. This switch allows greater compatibility with existing systems by effectively limiting the maximum angle to 99.99°. When this switch is in the 'on' position, any angle greater than 99.99° will show as 99.99°.

OPT6 Option Switch 6 Hundredths Digit

This switch controls the inclusion of the hundredths digit in the output data string. Some less accurate sensors provide a Pitch and Roll data string with resolution to only 1/10th degree. This is also asked for by some NMEA compatible data formats. Placing this switch in the 'off' position will include the 1/100th degree data.

4.3 Data Output Information

The output data is configured in the following manner:

Baud Rate	9600
Data Bits	8
Stop Bits	1
Parity	None

5. Mounting Arrangements

5.1 OEM version

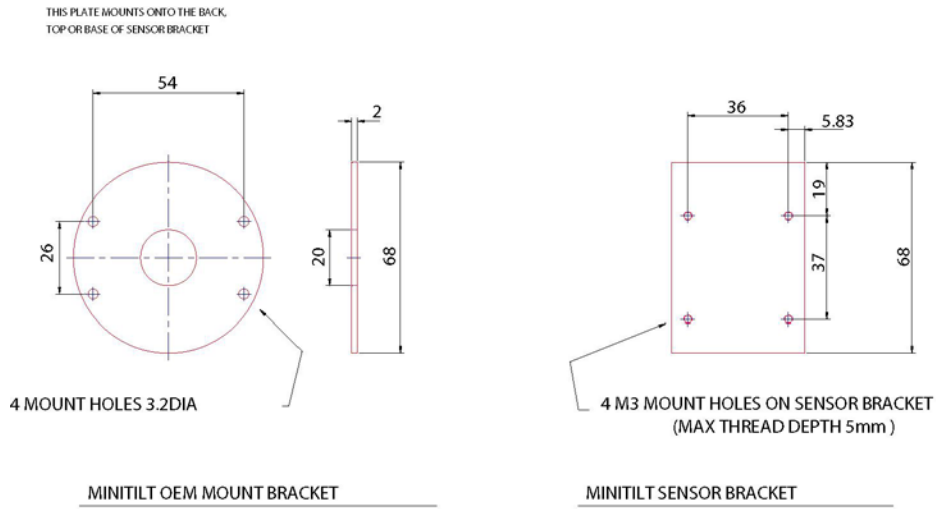

5.2 Surface and Subsea versions

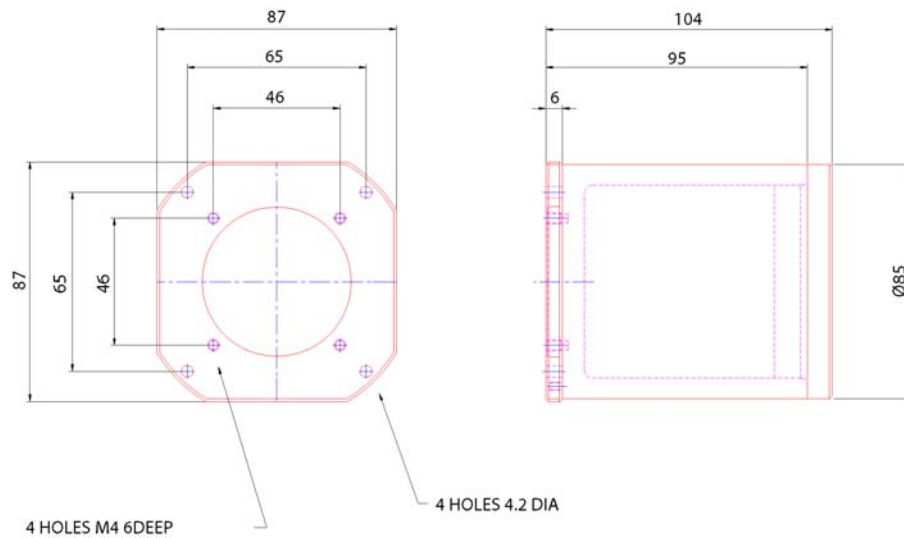

5.3 MiniTilt Zero Setting

The zero setting of all MiniTilt systems can be changed to any point at the factory. This allows for unusual mounting arrangements where the MiniTilt can be placed horizontally rather than vertically. In fact the zero point can be set to any mark on the 360° angle so even offset mounting arrangements can be handled.

6. Topside Display (optional)

6.1 The CDLtd Data Display Unit (DDU)

The CDLtd Data Display Unit (DDU)



The CDL DDU is a touch-screen device which allows the user to display the output from the MiniTilt module without the requirement for any other equipment.

The main display shows pitch and roll information while the four LEDs indicate the status of the MiniTilt module.

During normal operation the power LED should be lit, the pitch and roll LEDs should pulse regularly, and the error LED should remain unlit.

6.2 MiniTilt display software

The CDLtd DDU uses Microsoft Windows CE based software to display data from the MiniTilt module.

Tap the 'Next Display' button to cycle through the available pages detailed below.



The main display page shows current pitch and roll values and has check boxes to allow the user to select whether or not the hundreds and hundredths digits are displayed. These options do not affect the output from the Com ports. Simply tap the check boxes to choose between the display options.

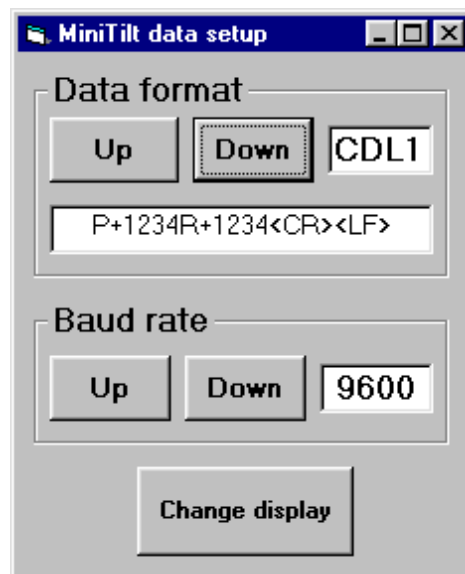

The MiniTilt data setup page has two pairs of buttons. The upper pair are used to select the format in which data is output from the Com ports. The selected format is displayed in the window below. The lower pair of buttons are used to select the baud rate of the data from the Com ports.

6.3 Connections

Mains

Power is supplied to the DDU via a standard IDC type connector at 110-240V AC.

Umbilical

Power to and data from the MiniTilt module are supplied via a 6 pin binder (RS part no. 261-5941)

Pin	Function
1	V in
2	Ground
3	Current Loop Hi
4	Current Loop Lo
5	N/C
6	N/C

Com 1 and Com 2

RS-232 format data is output from the DDU via two male 9-way 'D' type connectors and should be connected to a standard serial port using a null modem lead.

Pin	Function
3	Data
5	Ground

6.4 Setup procedure

1. Connect one end of the deck lead supplied to the MiniTilt module, and the other end to the 'Umbilical' socket on the DDU.
2. Connect the mains lead to the IDC socket and plug in to a suitable mains supply.
3. Switch on the supply, and switch on the DDU.

CONTACTING CDL

BY PHONE

Tel: +44 (0) 1224 706655
Fax: +44 (0) 1224 709840
Web: www.cd ltd.net

BY EMAIL

Mads Fogh	mf@cd ltd.net
Scott Thomson	st@cd ltd.net
Colin Crichton	cc@cd ltd.net
Gary Crichton	gc@cd ltd.net
Nick Murray	nm@cd ltd.net
Murray Leys	ml@cd ltd.net
Craig Spy	cs@cd ltd.net

OUT OF HOURS

Mads Fogh (Development Supervisor)	(mobile)	-	+44 (0) 7595 357197
Scott Thomson (Development Engineer)	(mobile)	-	+44 (0) 7590 642260
Colin Crichton (CEO)	(mobile)	-	+44 (0) 7803 034261
Gary Crichton (Technical Director)	(mobile)	-	+44 (0) 7803 909128
Nick J. Murray (Production Director)	(mobile)	-	+44 (0) 7711 505805
Murray Leys (Production Manager)	(mobile)	-	+44 (0) 7801 431986
Craig Spy (Development Engineer)	(mobile)	-	+44 (0) 7590 643243

In case of faults or queries please contact the Development personnel in the first instance.

